

# Quick Installation Manual

## 48V 100AH lithium battery pack



## Safety Precautions

In each stage of the operation of this lithium battery pack, the following general safety precautions must be followed. Failure to follow these precautions or the specific warnings described in other parts of this manual will violate safety standards regarding the design, manufacture, and use of lithium battery packs. The company does not assume any responsibility for users' non-compliance with these precautions.

### **WARNING:**

- The battery module must be used in conjunction with the same manufacturer, and the mixed use of batteries from different manufacturers is strictly prohibited.
- Check whether the battery module is leaking, the poles and sampling connectors are damaged, etc.; if there is any abnormality, please stop using it.
- It is strictly forbidden to stack the whole trailer battery with fork plate during transportation and storage. It is forbidden to stack battery modules when installing and transporting batteries. There are positive and negative lead terminals or sampling line lead ends, and it is strictly forbidden to squeeze, stack and place them down.
- The 48V battery system supports parallel use, and serial use is strictly prohibited.
- It is forbidden to use or leave the battery module near high temperature and high heat sources, away from fire and water sources.
- It is forbidden to disassemble the battery module, knock, throw or step on the battery module, do not install substitute parts on the battery module by yourself, or perform any unauthorized modification.
- Disassemble and demolish the BMS and white tamper-evident stickers without permission are not warranty.
- The "positive" and "negative" marks are printed on the module. The battery polarity should be correctly determined. It is strictly forbidden to reverse or short-circuit the battery.
- Insulation tools and gloves should be used during installation and transportation, and metal-containing conductors such as watches, bracelets (bracelets), and rings should be removed from the wrist to prevent electric shock and short-circuit the positive and negative poles. During installation, the battery module pole needs to be insulated and protected. If the pole is close to the conductor such as the battery rack, the battery pole or battery rack needs to be insulated and protected.
- The recommended transportation method is for two people to carry it at the same time, and the transportation tool is a safety rope or a load-bearing net bag. It is necessary to bring the battery box to the site. Violent construction is strictly prohibited to damage the product.
- Installation and maintenance requirements. After the battery module is installed on the battery rack, the poles and sampling line connectors are required to be able to achieve positive maintenance.
- If the battery pack emits peculiar smell, heat, deformation, discoloration or any other abnormal phenomenon during use, immediately disconnect the electrical appliances and inverter, and stop using it.
- Always use a dry cloth to clean the device housing. Do not clean the inside of the instrument.
- Do not block the ventilation holes of the equipment.
- Please read this installation manual carefully before installation, if you have any questions, please contact us.

## Installation environment requirements

Lithium battery packs are allowed to be used indoors and in low-condensation areas. The following table shows the general environmental requirements.

<u>Environmental</u>	<u>requirements</u>
Charging temperature	0°C~45°C
Discharge temperature	-10~55°C
Operating humidity	20%~85% (non-condensing)
Storage temperature	-20°C~75 °C
Altitude	Operating altitude up to 2000 meters

# Chapter 1 Specification Parameter Table

NO	Item		Specification
1	Total power consumption		4.8KWH
	Model		48V100Ah
2	Rated Capacity		Min. :100Ah
			Typical:100Ah
3	Internal Impedance		$\leq 150\text{mohm}$
4	Nominal Voltage		48V
5	Charging Voltage		54V
6	Charging Method		CC&CV
	Standard Charging Process		0.2C (CC) charge to 54V, when 54V(CV) is reached, charge rate will reduce to 0.02C(A) for full charge
7	Discharging Method		Constant current discharge
8	Standard Discharge method		Cells should be discharged at a constant current of 0.2C to 42V at 20° C $\pm$ 5° C
9	Standard discharge capacity		$\geq 100\text{Ah}$
10	Max. Continuous Discharge Current		100A
11	Discharge Cut-Off Voltage		42V
12	Battery Weight		$\leq 45\text{KG}$
13	Battery Cycle Life		$\geq 1800$ Cycles (85% DOD discharge)
14	Operating Temperature	Discharge	-20° C to 55° C
		Charge	0° C to 45° C
		Storage	10° C to 30° C
15	Storage temperature	Within 1 month	- 5° C ~ +45° C
		Within 3 month	- 5° C ~ +35° C
		Within 6 month	0° C ~ +35° C

# Chapter 2 Inspection and Installation

## 2.1 Confirm package contents

Open the package and check the contents of the box before operation. If there is any discrepancy, missing or appearance wear, please contact the manufacturer as soon as possible.

Equipment	Quantity	Model	Remarks
Lithium battery pack	1 set	48V/100AH	
Factory inspection report	1 serving	-	Test report of this battery pack before leaving the factory
Certificate of conformity	1 piece	-	-

## 2.2 Size and panel introduction

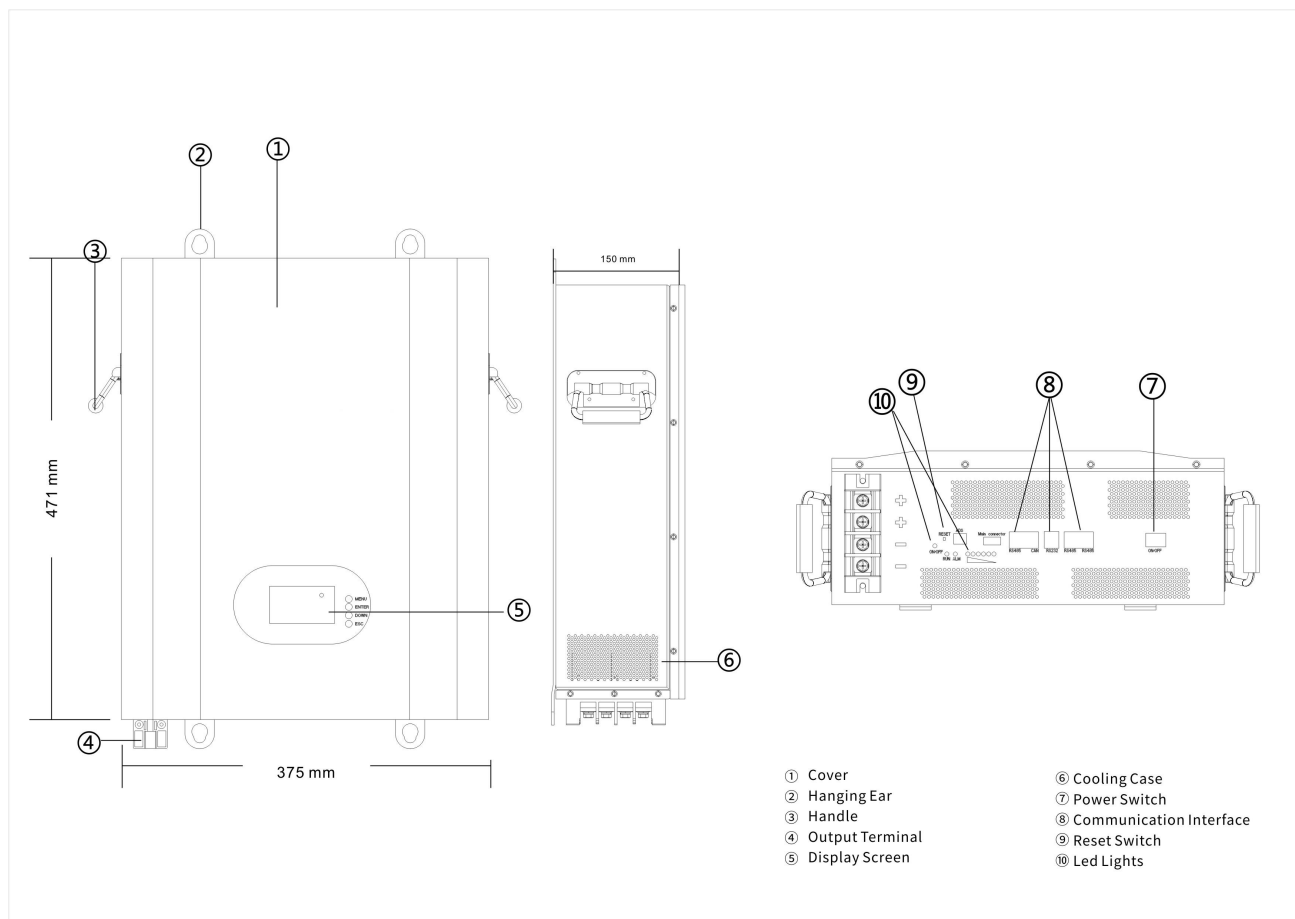

## 2.3 Installation fixed

The screw holes of the lithium battery pack can be directly installed with the wall or fixed objects with screws.

## 2.4 Connect the power line

To prevent electric shock and damage to the lithium battery pack, please observe the following precautions:

- Before connecting the power cable, please cut off the Power switch of the battery pack in the Off state and the power supply of the external connected equipment in the off state to avoid the risk of fire and electric shock during the connection process.
- Please confirm that the load full power current is not higher than the battery pack charge and discharge current range
- Please confirm the maximum current that the power line can withstand. The cable current must be higher than the maximum output current of the load.

The same model and the same capacity can support parallel connection, and different models and models are prohibited from parallel connection

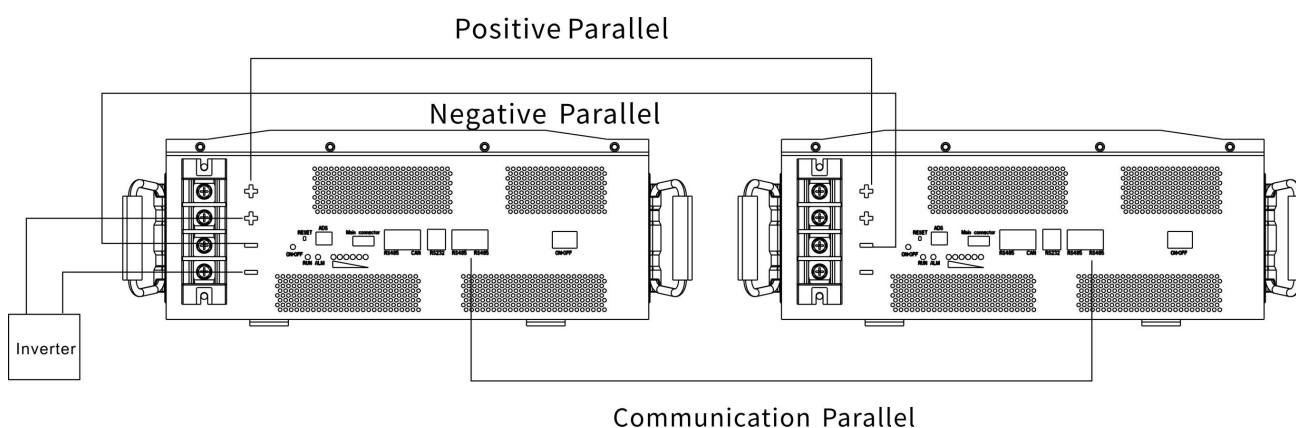

# Chapter 3 Related Functions

## 3.1 LED indication

Table 1 LED working status indication









Status	Normal/ Alarm/ Protection	ON/ OFF	RUN	ALM	Battery capacity indicator LED						Description	
												
Shutdown	Dormant	OFF	OFF	OFF	OFF	OFF	OFF	OFF	OFF	OFF	OFF	All off
Standby	Normal	ON	Flash1	OFF	According to battery capacity indicator						Standby mode	
	Alarm	ON	Flash1	Flash3	According to battery capacity indicator						Module low voltage	
Charge	Normal	ON	ON	OFF	According to battery capacity indicator (The highest battery capacity indicator LED flashes2)						The highest battery capacityLED flashes (flashing2); ALM does not flash when overcharge alarm	
	Alarm	ON	ON	Flash3	According to battery capacity indicator (The highest battery capacity indicator LED flashes2)						The highest battery capacityLED flashes (flashing2); ALM does not flash when overcharge alarm	
	Overcharge protection	ON	ON	OFF	ON	ON	ON	ON	ON	ON	ON	If there is no mains power, the indicator turns to standby
	Temperature,over current, failure protection	ON	OFF	ON	OFF	OFF	OFF	OFF	OFF	OFF	OFF	Stop charging
Discharge	Normal	ON	Flash3	OFF	According to battery capacity indicator							
	Alarm	ON	Flash3	Flash3	According to battery capacity indicator							
	Undervoltage protection	ON	OFF	OFF	OFF	OFF	OFF	OFF	OFF	OFF	OFF	Stop discharge
	Temperature,over current,short circuit,reverse connection, failure protection	ON	OFF	ON	OFF	OFF	OFF	OFF	OFF	OFF	OFF	Stop discharge
Invalidation		OFF	OFF	ON	OFF	OFF	OFF	OFF	OFF	OFF	OFF	Stop charging and discharging

Table 2 Description of capacity indication

Status		Charge						Discharge					
Capacity indicator		L6	L5	L4	L3	L2	L1	L6	L5	L4	L3	L2	L1
Capacity (%)	0~16.6%	OFF	OFF	OFF	OFF	OFF	Flash2	OFF	OFF	OFF	OFF	OFF	ON
	16.6~33.2%	OFF	OFF	OFF	OFF	Flash2	ON	OFF	OFF	OFF	OFF	ON	ON
	33.2~49.8%	OFF	OFF	OFF	Flash2	ON	ON	OFF	OFF	OFF	ON	ON	ON
	49.8~66.4%	OFF	OFF	Flash2	ON	ON	ON	OFF	OFF	ON	ON	ON	ON
	66.4~83.0%	OFF	Flash2	ON	ON	ON	ON	OFF	ON	ON	ON	ON	ON
	83.0~100%	Flash2	ON	ON	ON	ON	ON	ON	ON	ON	ON	ON	ON
RUN indicator ●		ON						Flash (Flash3)					

## 3.2 Buzzer action description

In the event of a fault, it will beep 0.25S every 1S; in protection, it will beep 0.25S every 2S (except for overvoltage protection); when it is alarmed, it will beep every 3S (except overvoltage alarm);

The buzzer function can be enabled or disabled by the host computer, and the factory default is disabled.

## 3.3 Description of reset button

- When the BMS is in dormant state, press the button (3~6S) and release it, the protection board is activated, and the LED indicators will light up for 0.5 seconds from "RUN".
- When the BMS is in the active state, press the button (3~6S) and then release it, the protection board will be dormant, and the LED indicator will turn on for 0.5 seconds from the lowest battery light.
- When the BMS is in the active state, press the button (6~10S) and then release it, the protection board is reset, and all the LED lights are on for 1.5 seconds at the same time.



- After the BMS is reset, the parameters and functions set by the upper computer are still retained. If you need to restore to the initial parameters, you can use the "restore default values" of the upper computer to achieve, but the relevant running records and stored data remain unchanged (such as capacity, cycle times) , Protection of records, etc.).

## 3.4 Sleep and wake up

### 3.4.1 Sleep

When any one of the following conditions is met, the system enters low power consumption mode:

- 1) Single or overall over-discharge protection has not been released within 60 seconds.
- 2) Press the button (3~6S) and release the button.
- 3) The lowest cell voltage is lower than the sleep voltage, and the duration reaches the sleep delay time (at the same time, no communication, no protection, no balance, no current).
- 4) Standby time exceeds 24 hours (no communication, no charge and discharge, no mains).
- 5) Force shutdown through the host computer software.

Before entering sleep, make sure that the input terminal is not connected to an external voltage, otherwise it will not be able to enter the low power consumption mode.

### 3.4.2 Wake up

When the system is in low-power mode and meets any of the following conditions, the system will exit low-power mode and enter normal operation mode:

- 1) When the charger is connected, the output voltage of the charger must be bigger than 48V.
- 2) Press the button (3~6S) and release the button.

**Remarks: After single or overall over-discharge protection, it enters low-power mode, wakes up every 4 hours and turns on the charge and discharge MOS. If it can be charged, it will exit the sleep state and enter normal charging; if it cannot be charged after 10 consecutive automatic wakeups, it will no longer wake up automatically.**

**When the system is defined as the end of charging, the recovery voltage is not reached after 2 days of standby (standby time setting value), and the charging is forced to resume until the end of charging again**

### 3.5 RS485 Communication

With dual RS485 interfaces, you can view PACK information, and the default baud rate is 9600bps. If you need to communicate with the monitoring device through RS485, the monitoring device acts as the host, polling data according to the address,

#### DIP switch settings

When PACKs are used in parallel, different PACKs can be distinguished by setting the address of the DIP switch on the BMS. Avoid setting the addresses to the same. Refer to the table below for the definition of the BMS DIP switch.

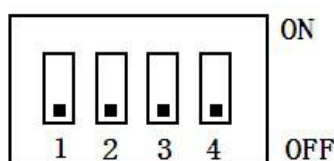

Address	DIP switch position				Description
	#1	#2	#3	#4	
0	OFF	OFF	OFF	OFF	Single use
1	ON	OFF	OFF	OFF	Set as main pack1
2	OFF	ON	OFF	OFF	Set as slave pack2
3	ON	ON	OFF	OFF	Set as slave pack3
4	OFF	OFF	ON	OFF	Set as slave pack4
5	ON	OFF	ON	OFF	Set as slave pack5
6	OFF	ON	ON	OFF	Set as slave pack6
7	ON	ON	ON	OFF	Set as slave pack7
8	OFF	OFF	OFF	ON	Set as slave pack8
9	ON	OFF	OFF	ON	Set as slave pack9
10	OFF	ON	OFF	ON	Set as slave pack10
11	ON	ON	OFF	ON	Set as slave pack11
12	OFF	OFF	ON	ON	Set as slave pack12
13	ON	OFF	ON	ON	Set as slave pack13
14	OFF	ON	ON	ON	Set as slave pack14
15	ON	ON	ON	ON	Set as slave pack15

### 3.6 Interface definition

#### Interface icon

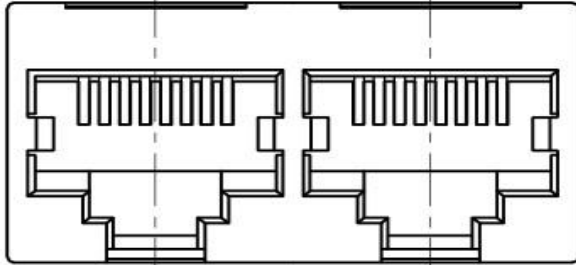

RS485 and CAN interface



dry contacts

pin3 to pin4: closed when low battery alarm;  
pin1 to pin2: closed when fault protection

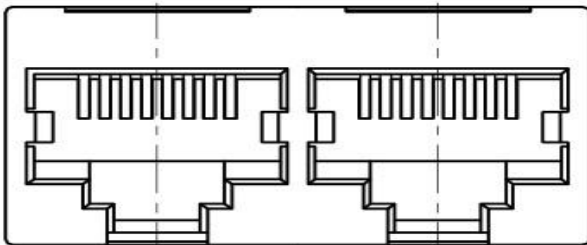

Parallel communication port

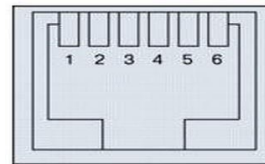

RS232 communication interface

RS485--Using 8P8C vertical RJ45 socket		CAN--Using 8P8C vertical RJ45 socket	
RJ45 pin	Definition description	RJ45 pin	Definition description
1、8	RS485-B1	9、10、11、14、16	NC
2、7	RS485-A1	12	CANL
3、6	GND	13	CANH
4、5	NC	15	GND

CAN and RS485 interface

RS485--Using 8P8C vertical RJ45 socket		RS485--Using 8P8C vertical RJ45 socket	
RJ45 pin	Definition description	RJ45 pin	Definition description
1、8	RS485-B	9、16	RS485-B
2、7	RS485-A	10、15	RS485-A
3、6	GND	11、14	GND
4、5	NC	12、13	NC

Parallel communication port

## Chapter 4 Simple Troubleshooting

### 4.1 Common abnormal phenomena of battery packs and troubleshooting methods

Failure phenomenon	Possible reason	Method of exclusion
BMS cannot be activated	The battery pack is seriously over-discharged and sleeps after under-voltage	Press the restart switch to restart and activate; Connect to the charger to activate
No output voltage	<ol style="list-style-type: none"> <li>1. Check whether there is alarm protection (voltage, current, temperature, etc.) through the screen or display lamp</li> <li>2. Whether there is external overload or short circuit</li> </ol>	<ol style="list-style-type: none"> <li>1. According to screen alarm processing</li> <li>2. Measure the output voltage after disconnecting the load</li> </ol>
BMS cannot communicate with the computer software	<ol style="list-style-type: none"> <li>1. Parallel BMS dial code address duplicate</li> <li>2. The communication serial port setting is incorrect</li> <li>3. The RS485 communication line sequence is incorrect</li> <li>4. Abnormal physical connection</li> </ol>	<ol style="list-style-type: none"> <li>1. When multiple units are connected in parallel, different addresses need to be set, detect and reset the BMS dialing address</li> <li>2. Set the correct serial port configuration according to our communication protocol</li> <li>3. Connect the communication line correctly as described in the installation manual</li> <li>4. Check that the physical connection of the communication circuit is normal</li> </ol>
Shorter discharge time	The ambient temperature is too low, the cell capacity is attenuated	<ol style="list-style-type: none"> <li>1. Increase the temperature of the use environment</li> <li>2. Turn on the battery for a period of time to let the battery cell heat up</li> </ol>
Can't charge	<ol style="list-style-type: none"> <li>1. Low battery temperature protection</li> <li>2. Over-discharge protection is not restored, and individual chargers cannot be started</li> </ol>	<ol style="list-style-type: none"> <li>1. Increase the temperature of the use environment</li> <li>2. Check whether the display unit is under voltage protection, output the connected voltage (series battery) to enable the charger to start charging</li> </ol>

Failure phenomenon	Possible reason	Method of exclusion
BMS cannot be activated	The battery pack is seriously over-discharged and sleeps after under-voltage	Press the restart switch to restart and activate; Connect to the charger to activate
No output voltage	1. Check whether there is alarm protection (voltage, current, temperature, etc.) through the screen or display lamp 2. Whether there is external overload or short circuit	1. According to screen alarm processing 2. Measure the output voltage after disconnecting the load
BMS cannot communicate with the computer software	1. Parallel BMS dial code address duplicate 2. The communication serial port setting is incorrect 3. The RS485 communication line sequence is incorrect 4. Abnormal physical connection	1. When multiple units are connected in parallel, different addresses need to be set, detect and reset the BMS dialing address 2. Set the correct serial port configuration according to our communication protocol 3. Connect the communication line correctly as described in the installation manual 4. Check that the physical connection of the communication circuit is normal
Shorter discharge time	The ambient temperature is too low, the cell capacity is attenuated	1. Increase the temperature of the use environment 2. Turn on the battery for a period of time to let the battery cell heat up
Can't charge	1. Low battery temperature protection 2. Over-discharge protection is not restored, and individual chargers cannot be started	1. Increase the temperature of the use environment 2. Check whether the display unit is under voltage protection, output the connected voltage (series battery) to enable the charger to start charging

## Quick Installation Manual

### 48V/51.2V -50AH/100AH Lithium Battery Pack

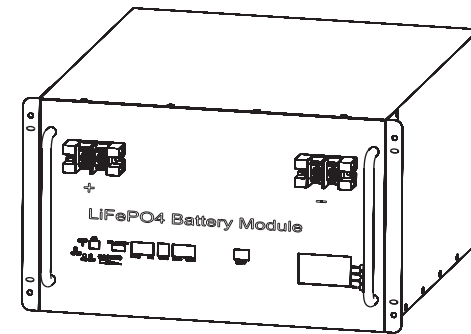

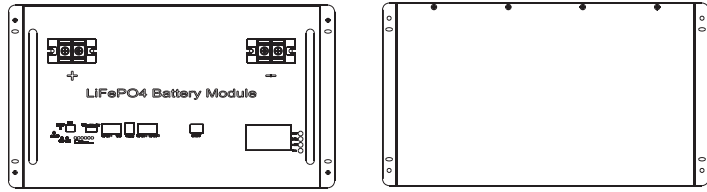

### Safety Precautions

In each stage of the operation of this lithium battery pack, the following general safety precautions must be followed. Failure to follow these precautions or the specific warnings described in other parts of this manual will violate safety standards regarding the design, manufacture, and use of lithium battery packs. The company does not assume any responsibility for users' non-compliance with these precautions.

### WARNING:

The battery module must be used in conjunction with the same manufacturer, and the mixed use of batteries from different manufacturers is strictly prohibited.

Check whether the battery module is leaking, the poles and sampling connectors are damaged, etc.; if there is any abnormality, please stop using it.

It is strictly forbidden to stack the whole trailer battery with fork plate during transportation and storage. It is forbidden to stack battery modules when installing and transporting batteries. There are positive and negative lead terminals or sampling line lead ends, and it is strictly forbidden to squeeze, stack and place them down.

The 48V battery system supports parallel use, and serial use is strictly prohibited.

It is forbidden to use or leave the battery module near high temperature and high heat sources, away from fire and water sources.

It is forbidden to disassemble the battery module, knock, throw or step on the battery module, do not install substitute parts on the battery module by yourself, or perform any unauthorized modification.

Disassemble and demolish the BMS and white tamper-evident stickers without permission are not warranty.

The "positive" and "negative" marks are printed on the module. The battery polarity should be correctly determined. It is strictly forbidden to reverse or short-circuit the battery.

Insulation tools and gloves should be used during installation and transportation, and metal-containing conductors such as watches, bracelets (bracelets), and rings should be removed from the wrist to prevent electric shock and short-circuit the positive and negative poles. During installation, the battery module pole needs to be insulated and protected. If the pole is close to the conductor such as the battery rack, the battery pole or battery rack needs to be insulated and protected.

The recommended transportation method is for two people to carry it at the same time, and the transportation tool is a safety rope or a load-bearing net bag. It is necessary to bring the battery box to the site. Violent construction is strictly prohibited to damage the product.

Installation and maintenance requirements. After the battery module is installed on the battery rack, the poles and sampling line connectors are required to be able to achieve positive maintenance.

If the battery pack emits peculiar smell, heat, deformation, discoloration or any other abnormal phenomenon during use, immediately disconnect the electrical appliances and inverter, and stop using it.

Always use a dry cloth to clean the device housing. Do not clean the inside of the instrument.

Do not block the ventilation holes of the equipment.

Please read this installation manual carefully before installation, if you have any questions, please contact us.

### 3.6 Interface definition

Interface icon

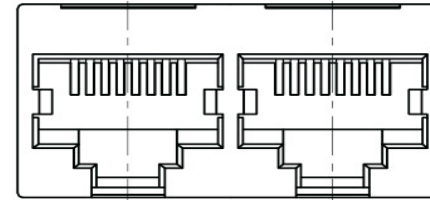

RS485 and CAN interface



1 2 3 4

dry contacts  
pin3 to pin4: closed when low battery alarm;  
pin1 to pin2: closed when fault protection

Parallel communication port

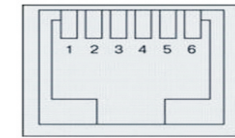
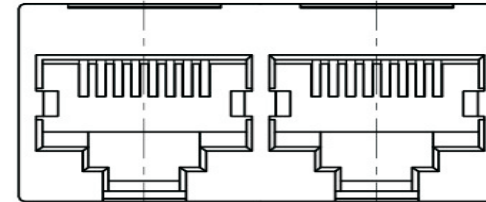

RS232 communication interface

RS485--Using 8P8C vertical RJ45 socket		CAN--Using 8P8C vertical RJ45 socket	
RJ45 pin	Definition description	RJ45 pin	Definition description
1、 8	RS485-B1	9、 10、 11、 14、 16	NC
2、 7	RS485-A1	12	CANL
3、 6	GND	13	CANH
4、 5	NC	15	GND

CAN and RS485 interface

RS485--Using 8P8C vertical RJ45 socket		RS485--Using 8P8C vertical RJ45 socket	
RJ45 pin	Definition description	RJ45 pin	Definition description
1、 8	RS485-B	9、 16	RS485-B
2、 7	RS485-A	10、 15	RS485-A
3、 6	GND	11、 14	GND
4、 5	NC	12、 13	NC

Parallel communication port

## 2.2 Size and panel introduction

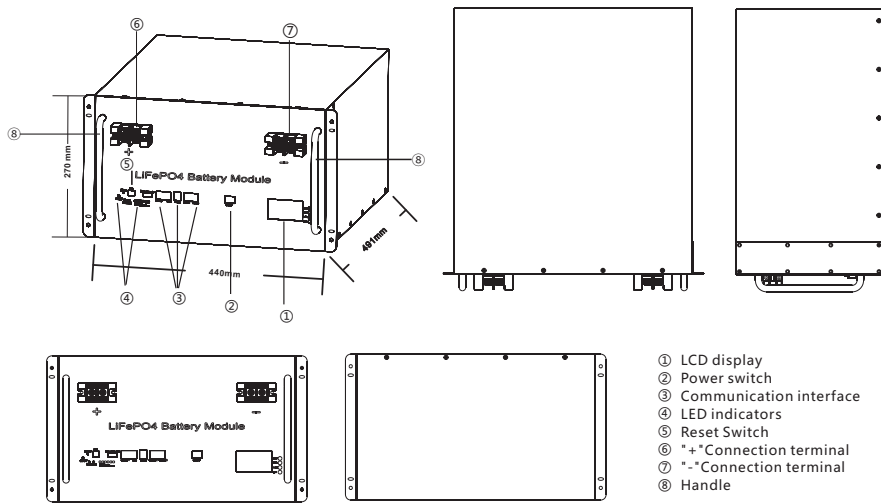

- ① LCD display
- ② Power switch
- ③ Communication interface
- ④ LED indicators
- ⑤ Reset Switch
- ⑥ "+ "Connection terminal
- ⑦ "- "Connection terminal
- ⑧ Handle

## Chapter 3 Related Functions

### 3.1 LED indication

Table 1 LED working status indication

Status	Normal/ Alarm/ Protection	ON/ OFF	RUN	ALM	Battery capacity indicator LED						Description	
Shutdown	Normal	OFF	OFF	OFF	OFF	OFF	OFF	OFF	OFF	OFF	OFF	All off
Standby	Normal	ON	Flash1	OFF	According to battery capacity indicator						Standby mode	
	Alarm	ON	Flash1	Flash3							Module low voltage	
Charge	Normal	ON	ON	OFF	According to battery capacity indicator (The highest battery capacity indicator LED flashes2)						The highest battery capacity LED flashes (flashing2); ALM does not flash when overcharge alarm	
	Alarm	ON	ON	Flash3								
	Overcharge protection	ON	ON	OFF	ON	ON	ON	ON	ON	ON		ON
Discharge	Temperature, over current, failure protection	ON	OFF	ON	OFF	OFF	OFF	OFF	OFF	OFF	OFF	Stop charging
	Normal	ON	Flash3	OFF	According to battery capacity indicator						Stop discharge	
	Alarm	ON	Flash3	Flash3								
Invalidation	Undervoltage protection	ON	OFF	OFF	OFF	OFF	OFF	OFF	OFF	OFF	OFF	Stop discharge
	Temperature, over current, short circuit, reverse connection, failure protection	ON	OFF	ON	OFF	OFF	OFF	OFF	OFF	OFF	OFF	Stop discharge
Invalidation		OFF	OFF	ON	OFF	OFF	OFF	OFF	OFF	OFF	OFF	Stop charging and discharging

Table 2 Description of capacity indication

Status	Charge						Discharge					
	L6	L5	L4	L3	L2	L1	L6	L5	L4	L3	L2	L1
Capacity indicator	●	●	●	●	●	●	●	●	●	●	●	●
Capacity (%)	0 ~ 16.6%	OFF	OFF	OFF	OFF	Flash2	OFF	OFF	OFF	OFF	OFF	ON
	16.6 ~ 33.2%	OFF	OFF	OFF	OFF	Flash2	ON	OFF	OFF	OFF	ON	ON
	33.2 ~ 49.8%	OFF	OFF	OFF	Flash2	ON	ON	OFF	OFF	ON	ON	ON
	49.8 ~ 66.4%	OFF	OFF	Flash2	ON	ON	ON	OFF	OFF	ON	ON	ON
	66.4 ~ 83.0%	OFF	Flash2	ON	ON	ON	ON	OFF	ON	ON	ON	ON
83.0 ~ 100%	Flash2	ON	ON	ON	ON	ON	ON	ON	ON	ON	ON	ON
RUN indicator *	ON						Flash(Flash3)					

### 2.3 Installation fixed

The screw holes of the lithium battery pack can be directly installed inside a rack or fixed objects with screws.

### 2.4 Connect the power line

To prevent electric shock and damage to the lithium battery pack, please observe the following precautions:

1. Before connecting the power cable, please cut off the Power switch of the battery pack in the Off state and the power supply of the external connected equipment in the off state to avoid the risk of fire and electric shock during the connection process.

2. Please confirm that the load full power current is not higher than the battery pack charge and discharge current range

3. Please confirm the maximum current that the power line can withstand. The cable current must be higher than the maximum output current of the load.

The same model and the same capacity can support parallel connection, and different models and models are prohibited from parallel connection

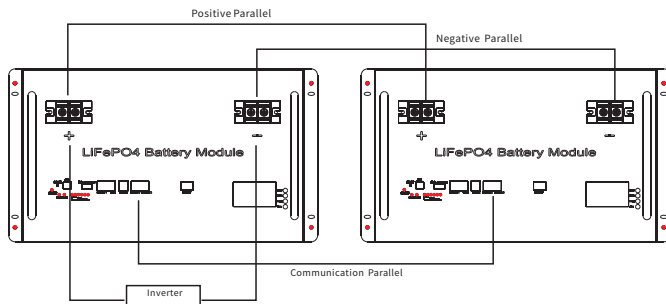

### 3.2 Buzzer action description

In the event of a fault, it will beep 0.25S every 1S; in protection, it will beep 0.25S every 2S (except for overvoltage protection); when it is alarmed, it will beep every 3S (except overvoltage alarm);

The buzzer function can be enabled or disabled by the host computer, and the factory default is disabled.

### 3.3 Description of reset button

When the BMS is in dormant state, press the button (3~6S) and release it, the protection board is activated, and the LED indicators will light up for 0.5 seconds from "RUN".

When the BMS is in the active state, press the button (3~6S) and then release it, the protection board will be dormant, and the LED indicator will turn on for 0.5 seconds from the lowest battery light.

When the BMS is in the active state, press the button (6~10S) and then release it, the protection is reset, and all the LED lights are on for 1.5 seconds at the same time.

After the BMS is reset, the parameters and functions set by the upper computer are still retained. If you need to restore to the initial parameters, you can use the "restore default values" of the upper computer to achieve, but the relevant running records and stored data remain unchanged (such as capacity, cycle times), Protection of records, etc.).

### 3.4 Sleep and wake up

#### 3.4.1 Sleep

When any one of the following conditions is met, the system enters low power consumption mode:

- (1)Single or overall over-discharge protection has not been released within 60 seconds.
- (2)Press the button (3~6S) and release the button.
- (3)The lowest cell voltage is lower than the sleep voltage, and the duration reaches the sleep delay time (at the same time, no communication, no protection, no balance, no current).
- (4)Standby time exceeds 24 hours (no communication, no charge and discharge, no mains).
- (5)Force shutdown through the host computer software.

Before entering sleep, make sure that the input terminal is not connected to an external voltage, otherwise it will not be able to enter the low power consumption mode.

#### 3.4.2 Wake up

When the system is in low-power mode and meets any of the following conditions, the system will exit low-power mode and enter normal operation mode:

- (1)When the charger is connected, the output voltage of the charger must be bigger than 48V.
- (2)Press the button (3~6S) and release the button.

Remarks: After single or overall over-discharge protection, it enters low-power mode, wakes up every 4 hours and turns on the charge and discharge MOS. If it can be charged, it will exit the sleep state and enter normal charging; if it cannot be charged after 10 consecutive automatic wakeups, it will no longer wake up automatically.

When the system is defined as the end of charging, the recovery voltage is not reached after 2 days of standby (standby time setting value), and the charging is forced to resume until the end of charging again

### 3.5 RS485 Communication

With dual RS485 interfaces, you can view PACK information, and the default baud rate is 9600bps. If you need to communicate with the monitoring device through RS485, the monitoring device acts as the host, polling data according to the address,DIP switch settings

When PACKs are used in parallel, different PACKs can be distinguished by setting the address of the DIP switch on the BMS. Avoid setting the addresses to the same. Refer to the table below for the definition of the BMS DIP switch.

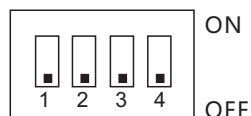

Address	DIP switch position				Description
	#1	#2	#3	#4	
0	OFF	OFF	OFF	OFF	Single use
1	ON	OFF	OFF	OFF	Set as main pack1
2	OFF	ON	OFF	OFF	Set as slave pack2
3	ON	ON	OFF	OFF	Set as slave pack3
4	OFF	OFF	ON	OFF	Set as slave pack4
5	ON	OFF	ON	OFF	Set as slave pack5
6	OFF	ON	ON	OFF	Set as slave pack6
7	ON	ON	ON	OFF	Set as slave pack7
8	OFF	OFF	OFF	ON	Set as slave pack8
9	ON	OFF	OFF	ON	Set as slave pack9
10	OFF	ON	OFF	ON	Set as slave pack10
11	ON	ON	OFF	ON	Set as slave pack11
12	OFF	OFF	ON	ON	Set as slave pack12
13	ON	ON	OFF	ON	Set as slave pack13
14	OFF	ON	ON	ON	Set as slave pack14
15	ON	ON	ON	ON	Set as slave pack15

### Installation environment requirements

Lithium battery packs are allowed to be used indoors and in low-condensation areas. The following table shows the general environmental requirements.

Environmental	Requirements
Charging temperature	0°C~45°C
Discharge temperature	-10~55°C
Operating humidity	20%~85% (non-condensing)
Storage temperature	-20°C~75 °C
Altitude	Operating altitude up to 2000 meters

### Chapter 1 Specification Parameter Table

NO	Item	Specification			
1	Total power storage (KWH)	2.4	4.8	2.56	5.12
	Model Name	48V50Ah	48V100Ah	51.2V50Ah	51.2V100Ah
2	Rated Capacity(AH)	50	100	50	100
3	Internal Impedance	≤ 150mohm			
4	Nominal Voltage	48		51.2	
5	Charging Voltage(Vdc)	54		57.6	
6	Charging Method	CC&CV			
	Standard Charging Process	0.2C (CC) charge to 54V,when 54V(CV)is reached, charge rate will reduce to 0.02C(A) for full charge		0.2C (CC) charge to 57.6V,when 57.6V(CV)is reached, charge rate will reduce to 0.02C(A) for full charge	
7	Discharging Method	Constant current discharge			
8	Standard discharge capacity	≥50Ah	≥100Ah	≥50Ah	≥100Ah
9	Max.Continuous Discharge Current(A)	50A	100A	50A	100A
10	Discharge Cut-Off Voltage	42V		44V	
11	Battery Cycle Life	≥1000 Cycles (85% DOD discharge)			
12	Operating Temperature	Discharge		-20°C to 55°C	
		Charge		0°C to 45°C	
		Storage		10°C to 30°C	
13	Storage temperature	Within 1 month		- 5°C ~ +45°C	
		Within 3 months		- 5°C ~ +35°C	
		Within 6 months		0°C ~ +35°C	

### Chapter 2 Inspection and Installation

#### 2.1 Inspection

Open the package and check the contents of the box before operation. If there is any discrepancy, missing or appearance wear, please contact the manufacturer as soon as possible.

Equipment	Quantity	Model	Remarks
Lithium battery pack	1 set		According to the order
User manual	1 set		